

Lineal Sconce

Installation Instructions

STRUCTURA

Warnings

CAUTION—risk of fire and this product must be installed in accordance with the applicable installation code by a person familiar with the construction and operation of the product and the hazards involved.

Suitable for wet locations.

Mounting orientation must have light source facing down.

Electrical service must be disconnected during installation.

Proper grounding is required to protect against shock and proper operation.

Tools Required

Philips screw driver

7/32" Allen wrench

Wiring tools and connectors

Sconce Installation

Step 1: Turn off power to location.

Step 2: Pull wire lead from junction box (by others) through center hole in mounting plate and mounting bracket.

Step 3: Secure mounting plate and mounting bracket to junction box using supplied hardware as shown in Figure A. Hardware for 3 1/2" and 4" octagonal boxes mount through both the mounting plate and mounting bracket with pan head screws. Hardware for 2" x 4" and 4" square boxes mount through mounting plate only using 6-32 and 8-32 flat head screws, respectively. Use 1/4"-20 pan head screws to secure mounting bracket to mounting plate.

Step 3: Silicone around the top and sides of the mounting plate and wall.

Step 4: Connect wire lead from junction box to wire pigtail coming out of luminaire in accordance to diagram shown on page 2 and push back into junction box.

Step 5: Slip luminaire onto mounting bracket by having the top of the luminaire close to the wall, slide onto the mounting bracket hook, and then push the bottom of the luminaire back.

Step 6: Secure luminaire to mounting bracket using supplied 8-32 set screws on the side of the luminaire standoff (4 places).

Step 7: Turn power back on.

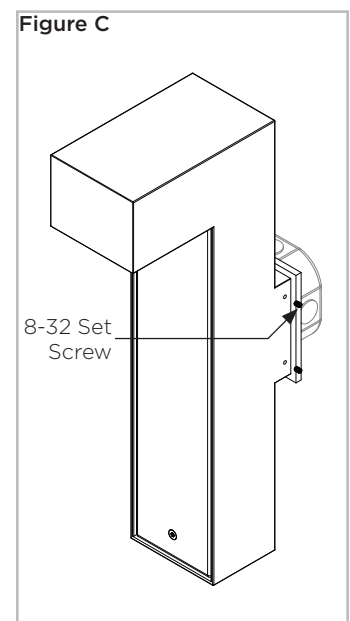
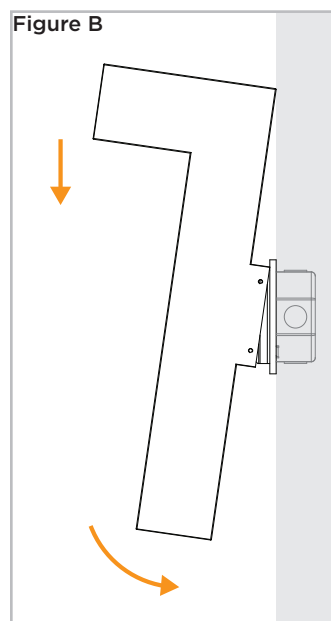
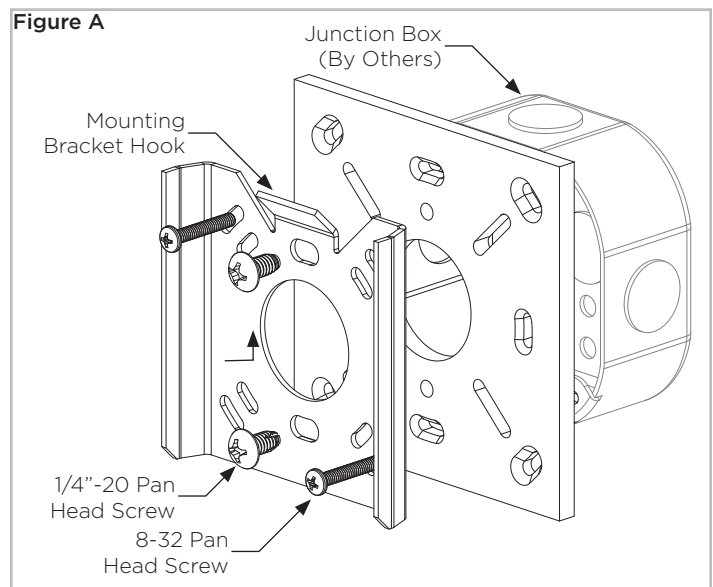
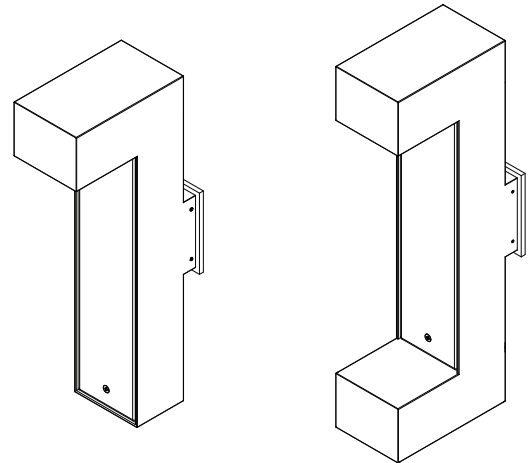

Luminaire Wiring

Step 1: While power is off, connect input power to luminaire pigtail as shown.

Step 2: Connect dimming wires to remote dimmer (by others) if applicable.

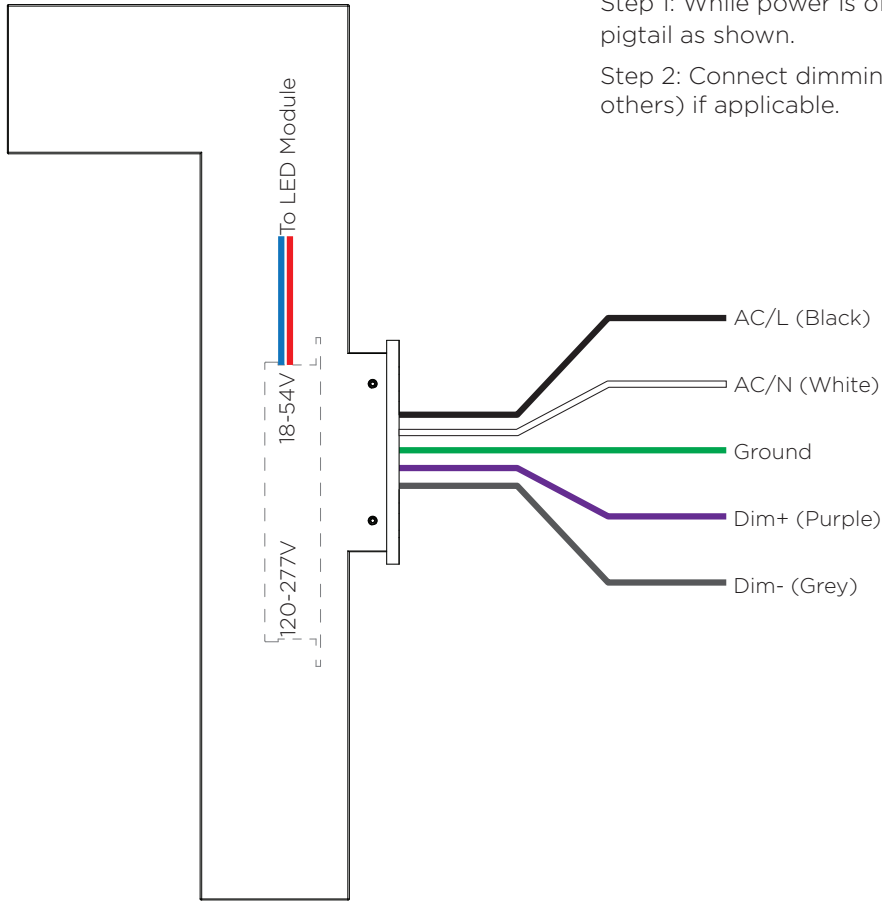

Base Detail

