

Catenary Mounting Installation Instructions

Warnings

CAUTION—risk of fire and this product must be installed in accordance with the applicable installation code by a person familiar with the construction and operation of the product and the hazards involved.

Suitable for wet locations.

Mounting orientation must have light source facing down.

Electrical service must be disconnected during installation.

Proper grounding is required to protect against shock and proper operation.

Tools Required

- 9/64" Allen wrench
- 5/64" Allen wrench
- 9/16" socket and wrench
- Wiring tools and connectors

Installation

Step 1: Turn off power to location.

Step 2: Attach mounting bracket to fixture as shown in Figure A.

Step 3: Lift mounting bracket above cable and rotate to set onto catenary in hooked area.

Step 4: Secure Mounting bracket and fixture location with Cable Clamp Bracket as shown in Figure C. Cable Clamp Bracket bend upwards for 1/4"-3/8" cable and downward for 3/8"-1/2" cable as shown in Figure D.

Step 5: Secure fixture angle with 8-32 set screws on side of Mounting Bracket. Connect power feed cable.

Step 6: Make wire connections as shown below in Figure C. If 0-10V dimming is not required, terminate ends from driver. Driver must be placed in metal enclosure.

Step 7: Turn power back on to location.

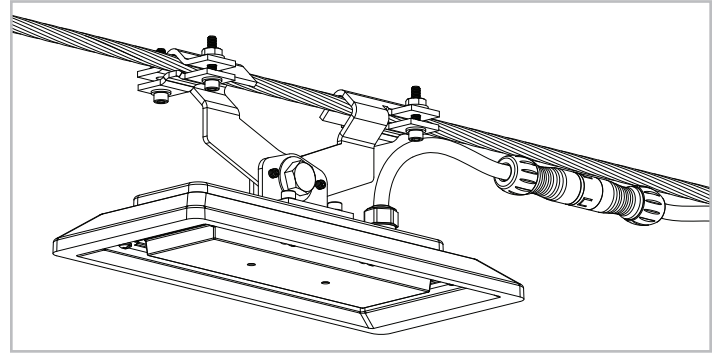

Figure A

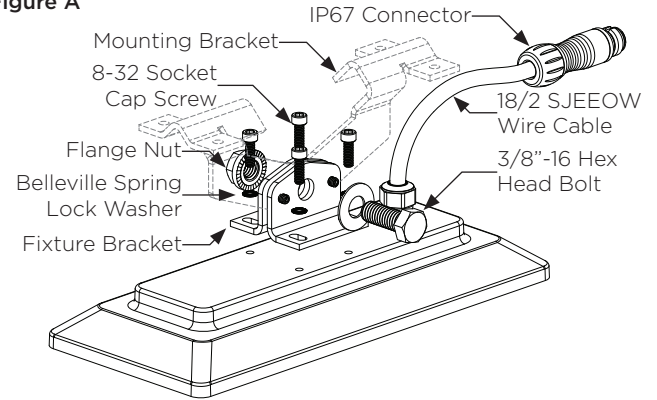

Figure B

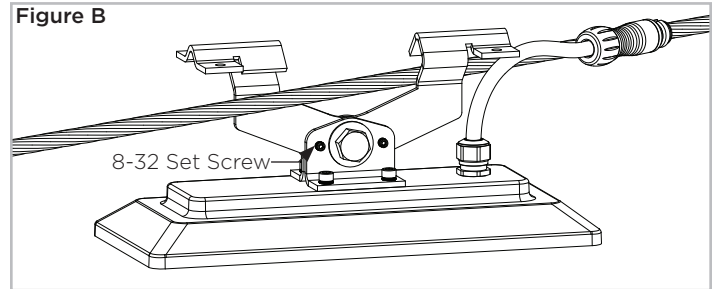

Figure C

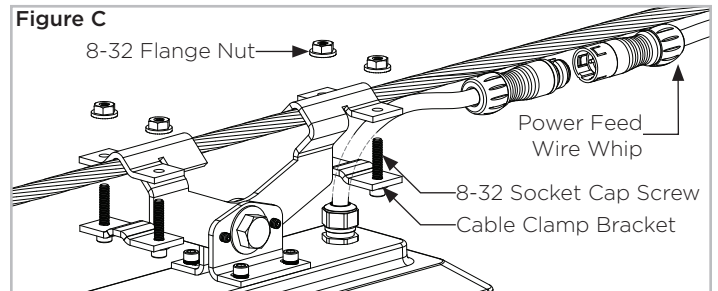

Figure D

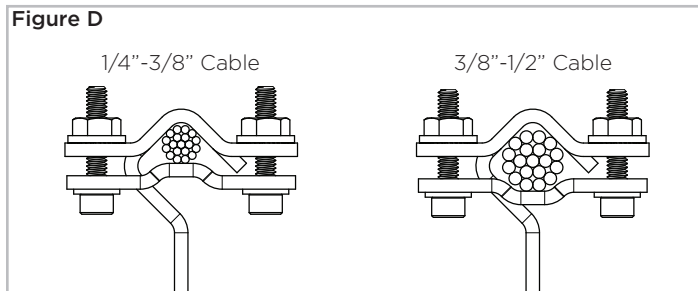

Figure E

