

Duo Bollard

Installation Instructions

STRUCTURA

Warnings

CAUTION—risk of fire and this product must be installed in accordance with the applicable installation code by a person familiar with the construction and operation of the product and the hazards involved.

Suitable for wet locations.

Mounting orientation must have light source facing down.

Electrical service must be disconnected during installation.

Proper grounding is required to protect against shock and proper operation.

Tools Required

T20 Tamper-resistant drive for panel screws

9/16" socket or wrench for anchor bolts

Philips drive for driver box lid

Wiring tools and connectors

Bollard Installation

Step 1: Turn off power to location.

Step 2: Remove (4) 8-32 tamper-resistant torx screws from lower accent panel. Safely set panel aside.

Step 3: Set bollard on to pre-installed anchor bolts from footing detail. Make sure bollard is level.

Step 4: Secure bollard with supplied (4) 3/8"-16 nuts and washers.

Step 5: Connect power to LED driver as shown on page 2 for driver wiring.

Step 6: Re-secure accent panel.

Step 7: Turn power back on.

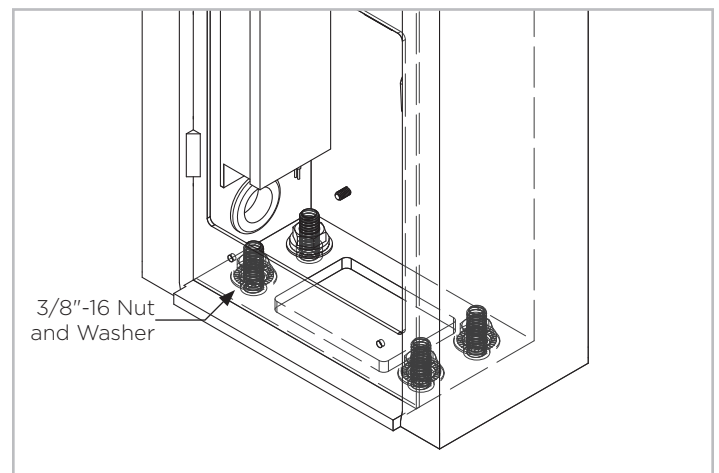
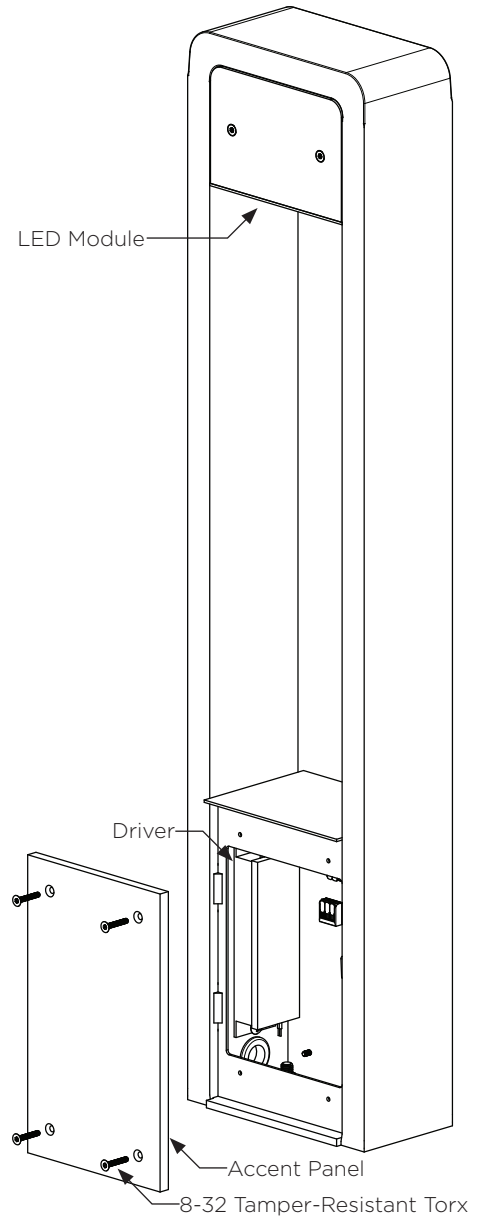

Duo Bollard

Installation Instructions

Bollard Wiring

Step 1: Connect input power to driver pigtail as shown above.

Step 2: Connect dimming wires to remote dimmer (by others) if applicable.

Step 3: Connect grounding wire to ground pigtail attached to driver box tray.

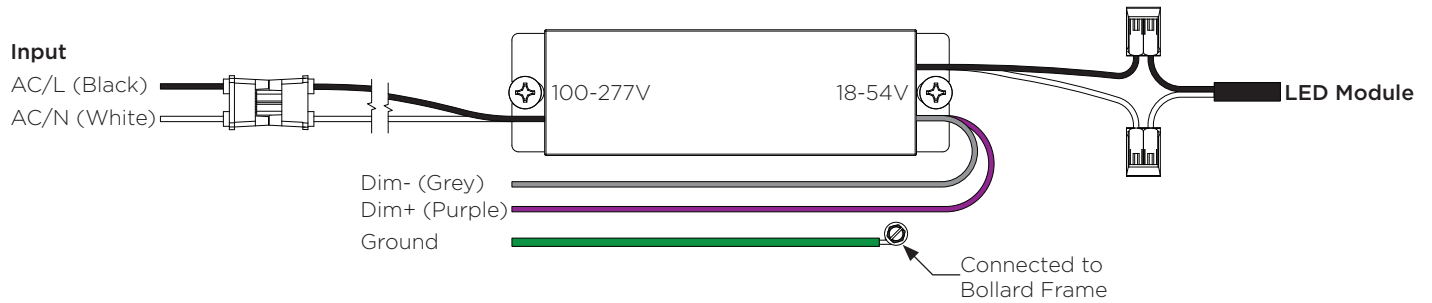

Base Detail

