

4

3

2

1

TABLE					
NOMINAL SIZE	TEMPLATE	OD	BC	T	P
*10	96512A	19.0	15.0	1.25	5

Pole has NOT been fully engineered. Sizing and pricing subject to change until Final Engineering is completed.

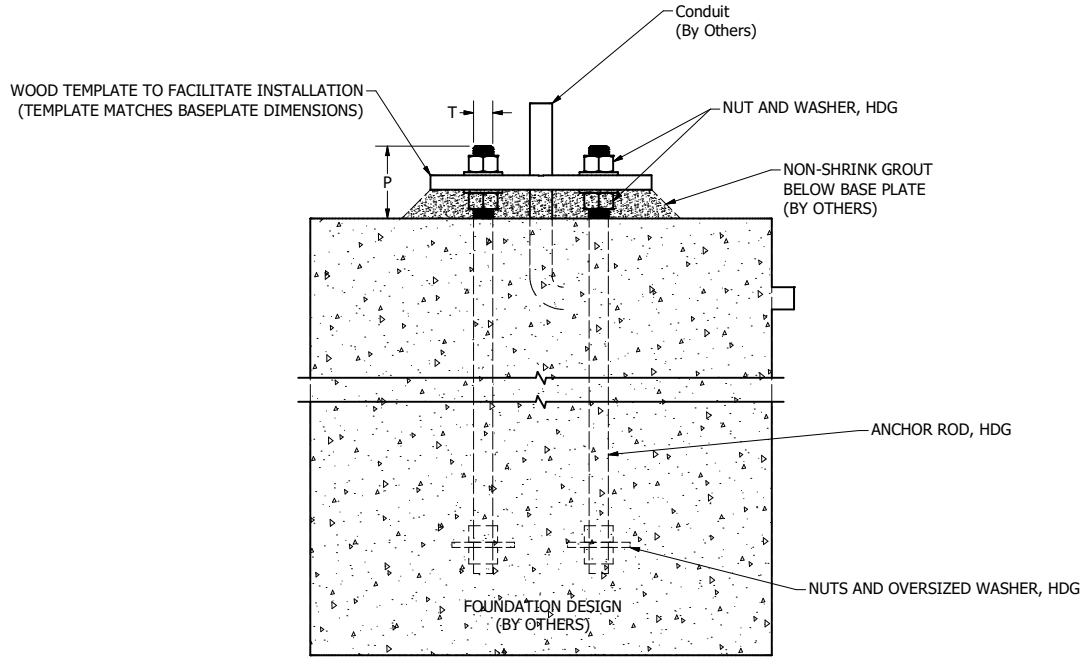
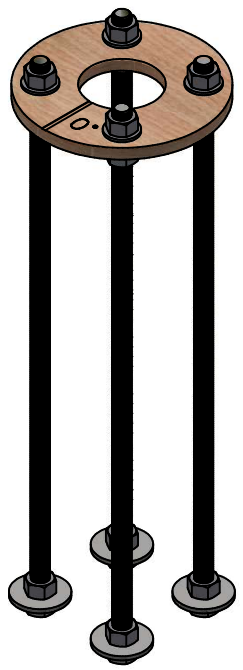
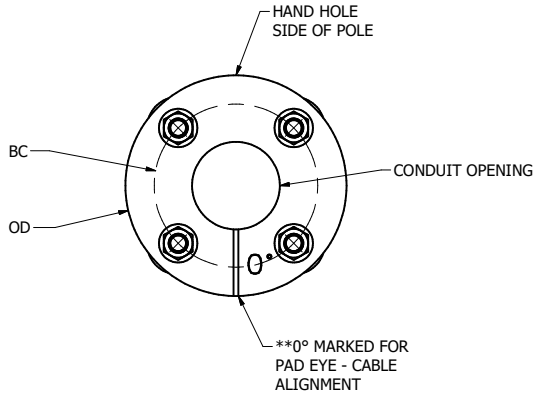

Assemble anchor bolts to template as shown in the drawing. Anchor bolts must be installed vertically straight. Level template in all directions and leave until foundation has cured. After foundation has cured, remove template and secure pole to anchor bolts.

Typical Pipe Pole Anchor Bolt Installation			
STAMP			
	9635 Widmer Rd. Lenexa, KS 66215		phone 913.390.8787 projects@structura.com
Pipe Poles			
SHEET NUMBER	REVISION	DATE	DRAWING
1 of 1		4/13/2021	Pipe - Anchor Bolt.idw

* Four (4) anchor bolts used for all poles up to 8" nominal size. Six (6) anchor bolts are used for 10", eight (8) for 12" and 14" poles, and twelve (12) for 16" poles.
 ** The 0° marking is only to be used as a reference for the front of the pole and does not necessarily mark the actual location of a pad eye. Refer to FINAL pole drawing(s) for actual pad eye location(s). Pad eyes must be oriented so that they are nearly in-line with cables.

4

3

2

1